SPECIAL PACKAGE FOR MULTILAYER MATRIX MODULES

1.0 SCOPE

This standard provides methods for the individual packaging of multilayer matrix boards in a rigid, clear, plastic box.

2.0 REFERENCES

- 2.1 Lockheed General Packaging Standard LPS 40-001
- 2.2 NAS Packaging Standard 3427

3.0 REQUIREMENTS

3.1 GENERAL

- 3.1.1 Each matrix board shall be packaged by one of the illustrated methods. Nonmechanical mounting is the preferred method (Figure 3, Figure 4, and Figure 5).
- 3.1.2 Regardless of the type of package used, all protruding pins shall be protected from distortion, bending or degradation by the method used to retain the boards within the plastic box.
- 3.1.3 Adequate clearances shall be maintained between the pins and the box to prevent damage during handling, shipment or storage, and to permit ease of insertion or removal of the board from the box. Minimum top/bottom clearance shall not be less than 1/4 inch, or less than 3/4 inch between the pins and the sides or ends of the box.
- 3.1.4 Each unit container shall be of minimum cube consistent with the requirements of this document and commensurate with the size of the matrix board.
- 3.1.5 Unit boxes without positive locking provisions shall be secured against inadvertent opening by applying reinforced pressure sensitive tape at a minimum of two places for hinged lids and four places for unhinged lids. Each strip of tape shall extend at least 2 inches on each side of the box sections (top/bottom).
- 3.1.6 Mounting hardware of material used to secure the matrix board in the box shall not abrade or cause damage to any element of the matrix assembly. Mounting method shall not obstruct from view the matrix assembly identification markings.
- 3.1.7 Inspection labels bearing appropriate inspection data/stamp shall be placed over opening seams of each box.

3.2 UNIT PACKAGING

3.2.1 Mechanical Mounting (See Figure 1 and Figure 2.)

Depending on the configuration of the matrix board, utilize the bolts/threaded inserts provided in the board design to secure the matrix board to angle supports/spacers and to the base of the box (Figure 1 and Figure 2). Tighten all nuts securely to retain board during ordinary handling/shipment.

3.2.2 Attaching Hardware

(Screws, nuts, washers, brackets, etc.) shall be provided to secure the matrix board at a minimum of two places or a maximum of four places. Such mounting points shall correspond with the attaching points provided by the board design. Provide washers on all screws passing through the plastic box and capture these screws on the inside with internal lockwashers, speednuts, etc.

3.2.3 Nonmechanical Mounting (See Figure 3, Figure 4, and Figure 5)

Depending on the location of projecting pins and the configuration of the matrix board, provide a minimum of two or a maximum of four separate retaining blocks made from expanded

polyethylene. Each block shall be slotted to sufficient depth and length to receive and support the edges of the board without contacting projecting pins. Minimum clearances between the pins and any side of the plastic box shall be in accordance with Paragraph 3.1.3.

3.2.4 Block Design Applications

Type 1 Designs (Figure 3, or Figure 4) shall employ four separate blocks of polyethylene cushion material (Paragraph 5.0), slotted to accommodate the matrix board at four unobstructed areas of the board. Slots provided shall be “snug” fitting to assure adherence to the board when the entire assembly (blocks and board) are removed from the box.

Type 2 Design (Figure 5) shall employ two separate blocks of polyethylene cushion material, slotted to accommodate the matrix board at two unobstructed areas of the board. Because of the limited available areas to retain the board, only two blocks are used.

NOTE: Blocks may be mitered, notched or otherwise altered to accommodate irregular board configurations without damaging the pins. Block designs shall fit the inside cavity of each box sufficiently to prevent undue movement.

3.3 INTERMEDIATE PACKAGING

3.3.1 Pack any number of unit packages uniformly in fiberboard containers.

3.3.2 Fill all voids with suitable dunnage blocking or bracing to prevent damage during handling/shipment.

3.4 PACKING

3.4.1 Pack any number of intermediate containers uniformly into each shipping container.

3.4.2 Shipping containers as packed, shall protect each item and package during ordinary handling and shipping and shall meet the minimum requirements of the common carriers for acceptance for safe transportation at the lowest rate to the point of delivery.

3.4.3 Intermediate containers which meet the requirements of Paragraph 3.4.2 may be used as shipping containers.

3.4.4 Enclose or attach a copy of packing slip to the shipping container.

3.5 MARKING

3.5.1 Unit Package Marking – Label or mark each package to show at least the part number per contracting document and supplier identity. If this data is readily visible and legible on each part inside the unopened container, the labeling or marking requirements is waived. Additional markings may be specified in the item detail specification or drawing.

3.5.2 Intermediate Packaging Marking – Label or mark each container to, at least, show part number per contracting document, supplier and quantity of parts.

3.5.3 Shipping Container Marking – Label or mark each container to show part number per contracting document, the LMSC contracting document number, supplier, destination and quantity of parts.

3.5.4 Special, precautionary and handling markings shall be applied as required.

4.0 QUALITY ASSURANCE

4.1 Packaging shall be accomplished in such a manner as to prevent physical damage to, or degradation of, the packaged items during delivery to the using activity. It shall be the prerogative of LMSC to return damaged items, at supplier’s expense, when such damage is attributable to improper or inadequate protection.

5.0 NOTES

5.1 The following information is intended as a guide or aid to suppliers in meeting requirements of this specification:

5.1.1 Material Specifications (Nonmechanical Mounting)

<u>Material</u>	<u>MIL-Spec</u>
<u>Expanded Polyethylene</u>	MIL-C-46842 (approx 2 lb density)

5.1.2 Unit Package Sources (Plastic Boxes)

Supplier

- Bradley Industries – Los Angeles, CA
- Creative Packaging Co. – Indianapolis, ID
- Gary Plastics Packaging Corp. – Bronx, NY
- Vicheck Plastics Co. – Middlefield, OH

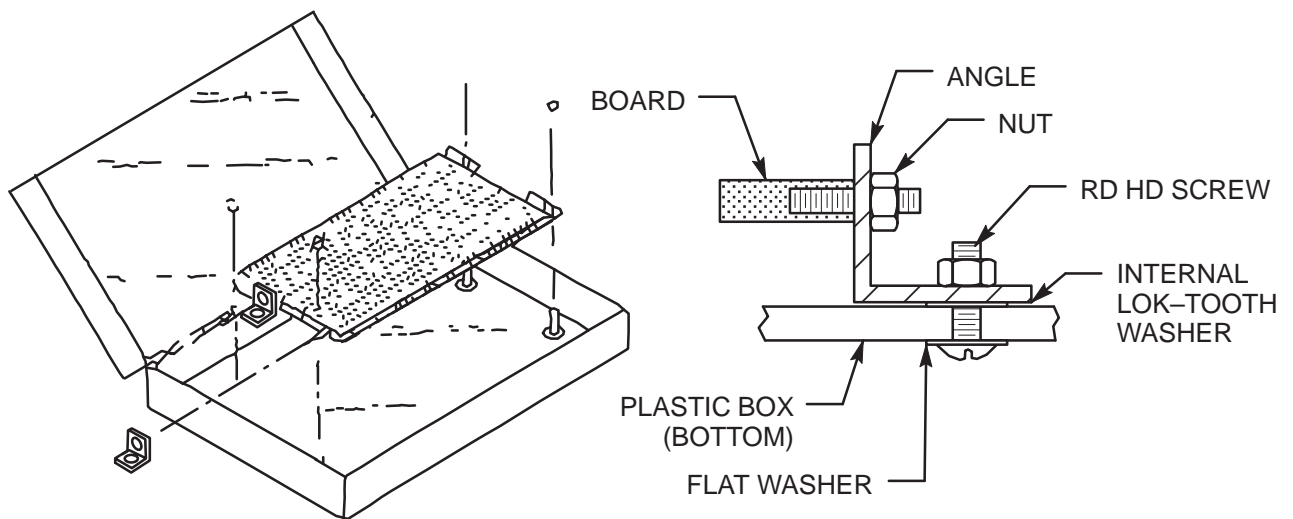

Figure 1. Mechanical Mounting (Angle Brackets)

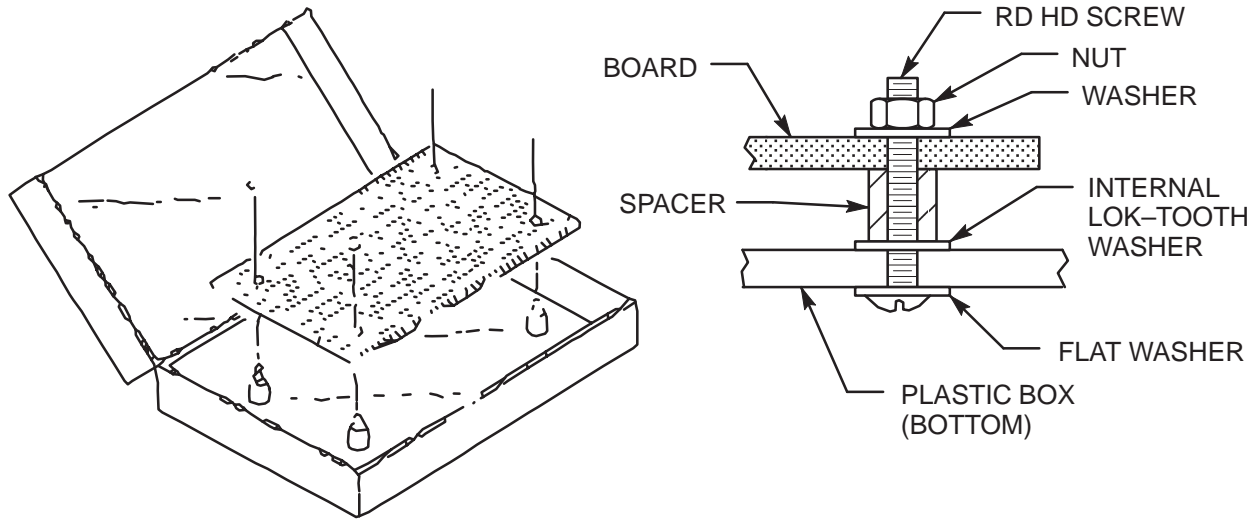
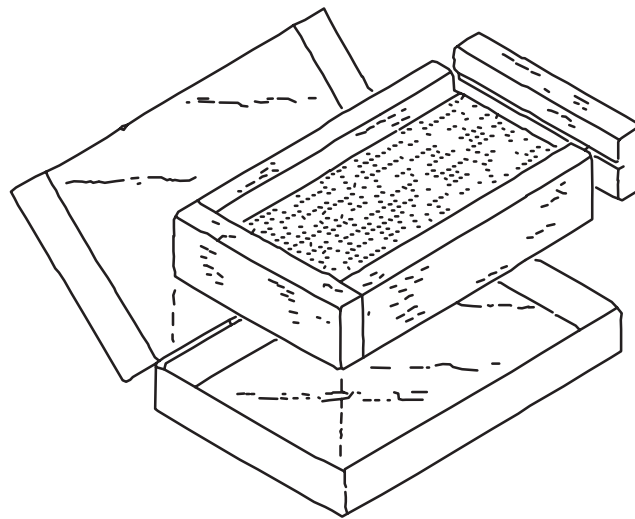

Figure 2. Mechanical Mounting (Spacers)

P10117-002



TYPE 1 DESIGN

Figure 3. Nonmechanical Mounting

P10118-001

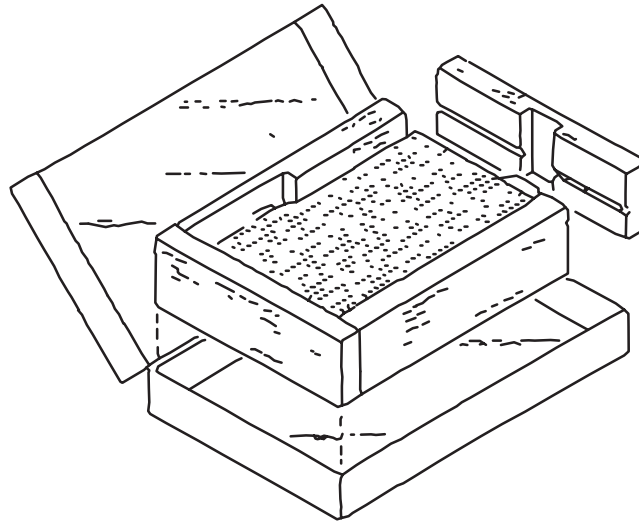

TYPE 1 DESIGN

Figure 4. Nonmechanical Mounting

P10118-002

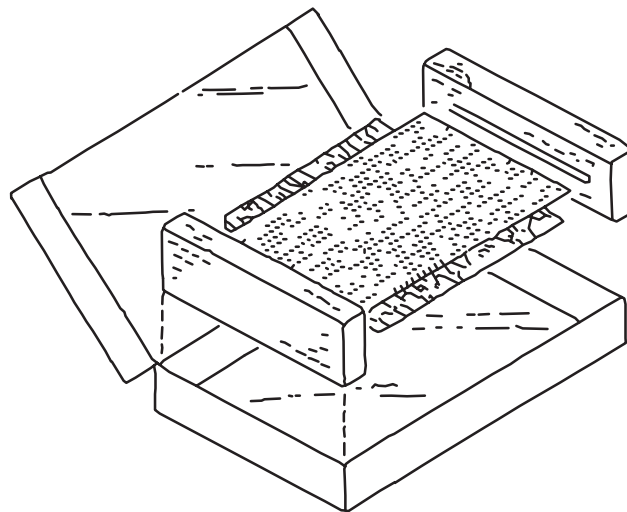

TYPE 2 DESIGN

Figure 5. Nonmechanical Mounting

P10118-003